



# VBW 1300 D-M02

## Çift Yüzey Temizleme ve Yan Frezeli PAH Kırma Fırçalama Makinesi

PVC

ALU

WOOD

Double Surface Cleaning and Side Milling Pah Breaking Brushing Machine  
Щеточный Станок для Двухсторонней Чистки и Боковой Фрезеровки

**TR** Panelin kaplama işleminden önce panel yüzeylerini kenar alt pah freze işlemeyle temizlemek için üst ve alt fırça ile donatılmış makinedir.

- Yüksekliği ayarlanabilir alt fırça modülü
- Alt kenarları temizlemek için kullanılan freze üniteleri
- Üst yüzeyi kusursuz temizleyen fırça üniteleri
- Panel ilerleme yönünün tersine dönen toz alma sulu fırça modülü

**EN** Before lamination panel double side cleaning and side milling pah breaking brushing machine

- Height adjustable sub brush module
- Milling units for cleaning the bottom edge
- Brush units for the perfect surface cleaning
- Dusting wet brush module, reverse the direction of panel advance

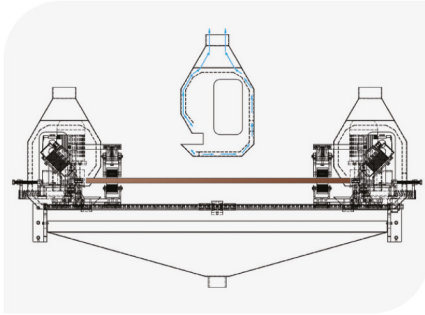
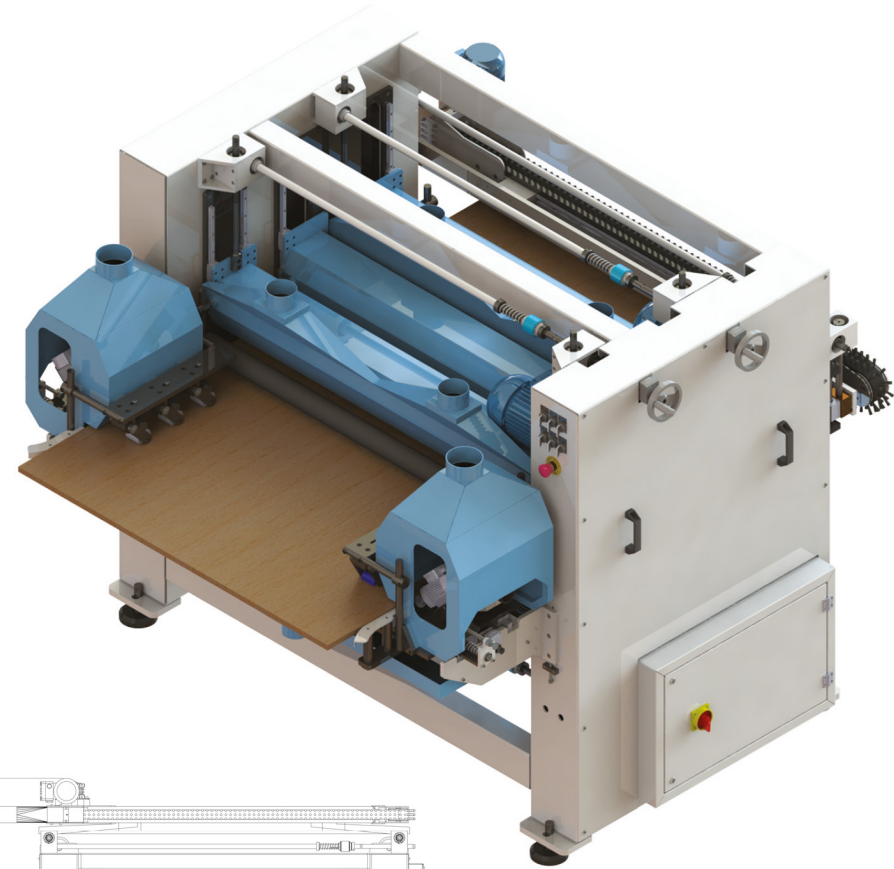

**Panelin Alt Kenarlarındaki  
Çapakları Kırma Freze Modülleri**  
The Milling Models for Breaking Burr in the  
Lower Edge of Panel

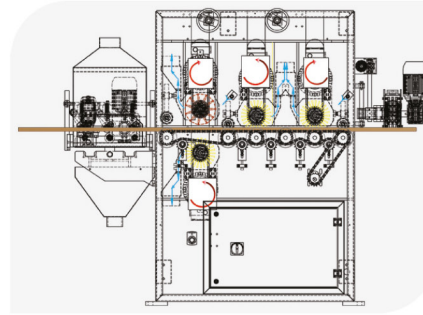

**Makineye Ait Teknik Çizim**  
Technical Drawing for the Machine

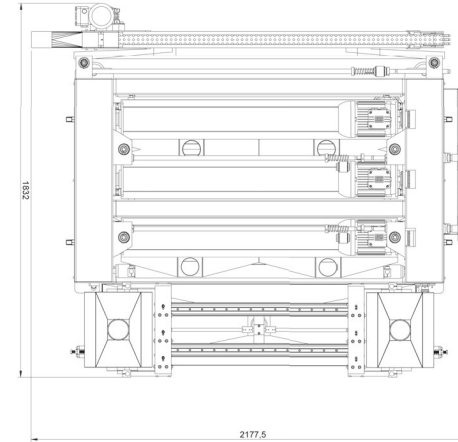

5-25  
m/dk



500-1300  
mm



1000  
kg

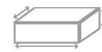

2.2x1.8x1.9  
m



5  
kW

[www.vermak.com.tr](http://www.vermak.com.tr)

